



ACCESSORY HANDBOOK

Sissy Bar Kit #6099-0022

Parts List

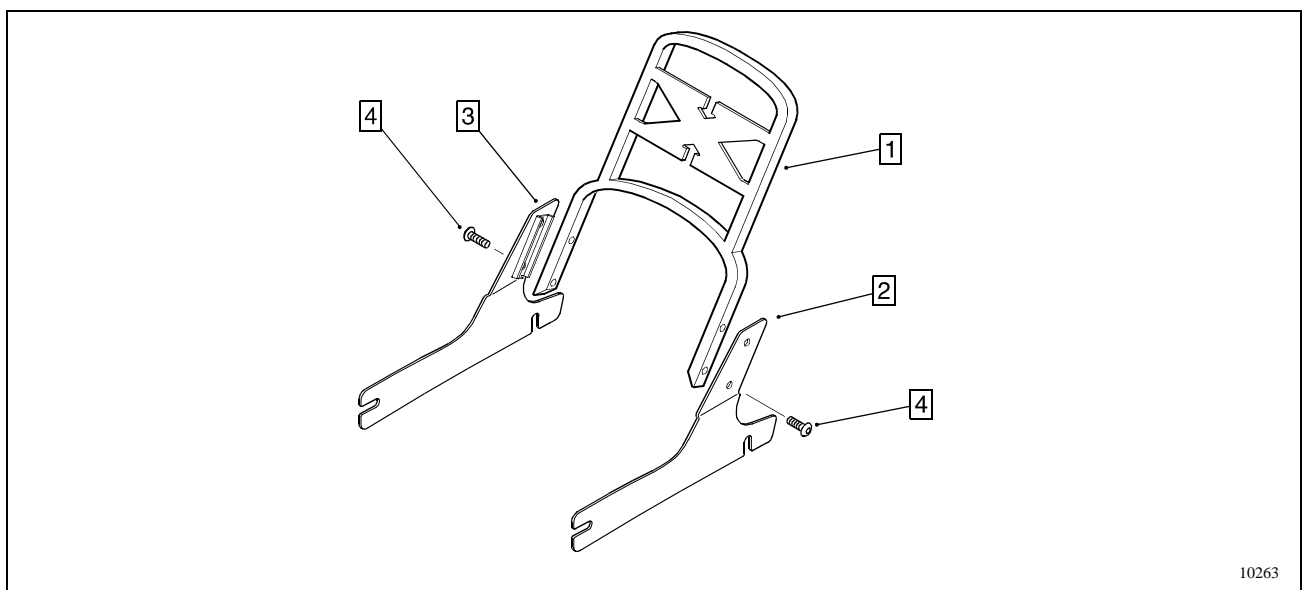

Figure 1

Item	Part No.	Description	Qty.	Item	Part No.	Description	Qty.
1.	7499-0004	Sissy Bar	1	3.	7499-0007	Plate - Side RH	1
2.	7499-0006	Plate - Side LH	1	4.	5199-0184	Screw - Hex. Button Hd.	4

Installation Instructions

Please read the Safety information on the following page before using your sissy bar.

- Loosen, but do not remove, the rear fender mounting screws on each side of the motorcycle (see Figure 2).

NOTICE

Each sissy bar side plate must be installed between the rear fender and the rear fender bracket. Be careful not to damage painted or plated surfaces during installation or removal.

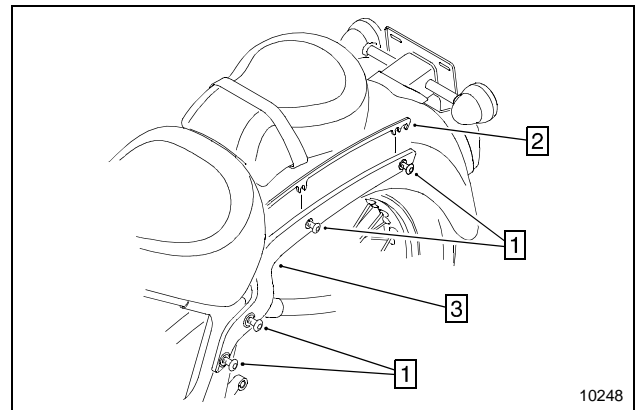

Figure 2

- Rear Fender Mounting Screws (8)
- Rear Fender Spacer
- Rear Fender Support

2. If your motorcycle has rear fender spacers, remove them before installing the sissy bar kit. Replace the spacers when operating the motorcycle without the sissy bar kit.

NOTICE

To prevent interference with the reflector, it may be necessary to remove the rear mounting screw (see Figure 3).

3. Attach the left side plate to the motorcycle by gently spreading apart the rear fender and left fender bracket. Guide the front slot of the left side plate under the reflector and over the front mounting screw. Guide the rear slot of the side plate over the rear mounting screw (see Figure 3).

4. Repeat Step 3 for the right side plate.

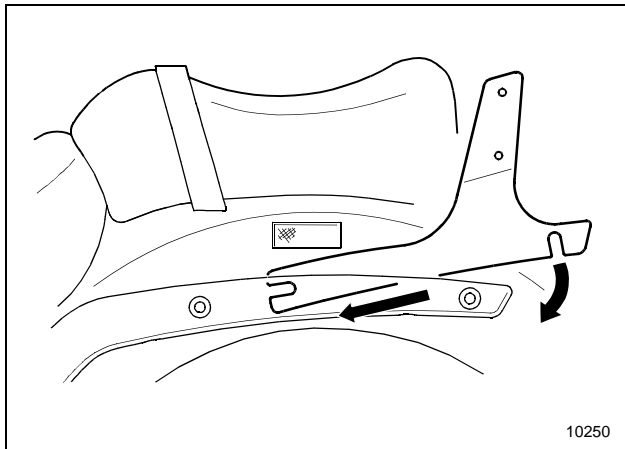

Figure 3

5. Position the sissy bar between the side plates and use the button hd. screws provided with this kit to attach the sissy bar to the side plates.

Torque: 15 ft. lbs

NOTICE

The “X” in the sissy bar is designed to provide additional support when using the sissy bar as a backrest, or with the optional backrest pad. When properly installed, the “X” should be flush with the forward surface of the sissy bar.

6. Tighten all rear fender mounting screws. Check fender alignment with the rear tire while tightening.

Torque: 35 ft. lbs.

7. Reverse this procedure to remove the sissy bar.

Safety

⚠ WARNING

Adding accessories and additional weight to the motorcycle can affect its stability, handling characteristics, and safe operating speed.

Be sure that the accessories and cargo are securely attached to the motorcycle before riding and whenever you take a break while riding. Accessories or cargo that shift while you are riding can create a sudden imbalance that can cause you to lose control of the motorcycle.



EXCELSIOR-HENDERSON MOTORCYCLE MANUFACTURING COMPANY

805 HANLON DRIVE · BELLE PLAINE, MINNESOTA 56011 · TELE: 612.873.7000/FAX: 612.873.7030 · www.excelsior-henderson.com
Excelsior-Henderson™, Super X™, Rider's Handbook™, and the X & Bar logo are registered trademarks of the Excelsior-Henderson Motorcycle Manufacturing Company. Loctite® is a registered trademark of the Loctite Corporation. Always ride safely, within the limits of the law, and your riding ability. Never ride under the influence of alcohol or drugs. Know your Excelsior-Henderson motorcycle and read your Rider's Handbook from cover to cover. We recommend you take a Motorcycle Safety Foundation Rider Education Course (for a course near you call 1.800.447.4700). We also recommend that you always wear a helmet, appropriate protective eyewear, and appropriate clothing, and that you insist your passenger does the same. However, we respect your right as an individual to make your own choice about the protective equipment you wear (within the limits of the law). Protect your privilege to ride by joining the American Motorcyclist Association.