



## Slash-Cut Muffler Kit #6099-0020

### Parts List

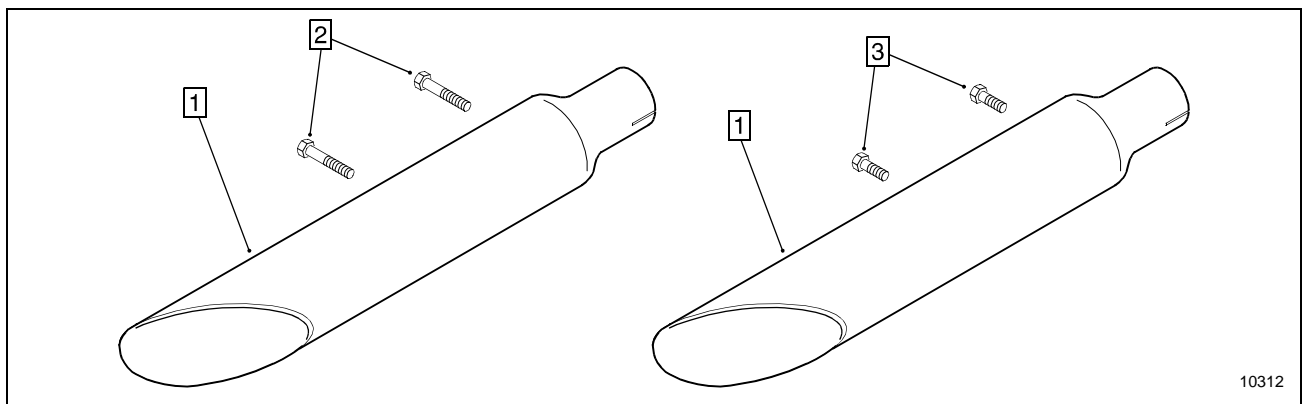

Figure 1

Item	Part No.	Description	Qty.	Item	Part No.	Description	Qty.
1.		Muffler - Slash-Cut*	2	3.	5199-0086	Screw - Front Muffler 1"	2
2.	5199-0090	Screw - Rear Muffler 2"	2				

\* Not Sold Separately

### Installation Instructions

#### NOTICE

These mufflers do not conform to EPA noise emissions regulations and are intended for closed course use only.

#### ⚠ WARNING

Under normal operating conditions, exhaust system components can be extremely hot. Allow engine to cool before installing the Slash-Cut mufflers.

1. Remove the existing rear cylinder and lower front cylinder exhaust system heat shields (see Figure 2).
2. Loosen both muffler clamps and slide them forward off of the existing mufflers.

3. Remove and discard the muffler mounting bolts, then slide the mufflers off of the header pipes.

#### NOTICE

These Slash-Cut mufflers are designed to use the existing muffler mounting bracket.

4. Slide the new mufflers onto the header pipes until their mounting holes align with the muffler mounting bracket. Start the muffler mounting bolts into each muffler. Use the shorter (1") screws provided with this kit for the front muffler, and the longer (2") screws provided with this kit for the rear muffler.
5. Slide each muffler clamp over the muffler and tighten the clamp.
6. Tighten the muffler mounting bolts.  
Torque: 30 ft. lbs.

7. Reinstall the exhaust system heat shields.

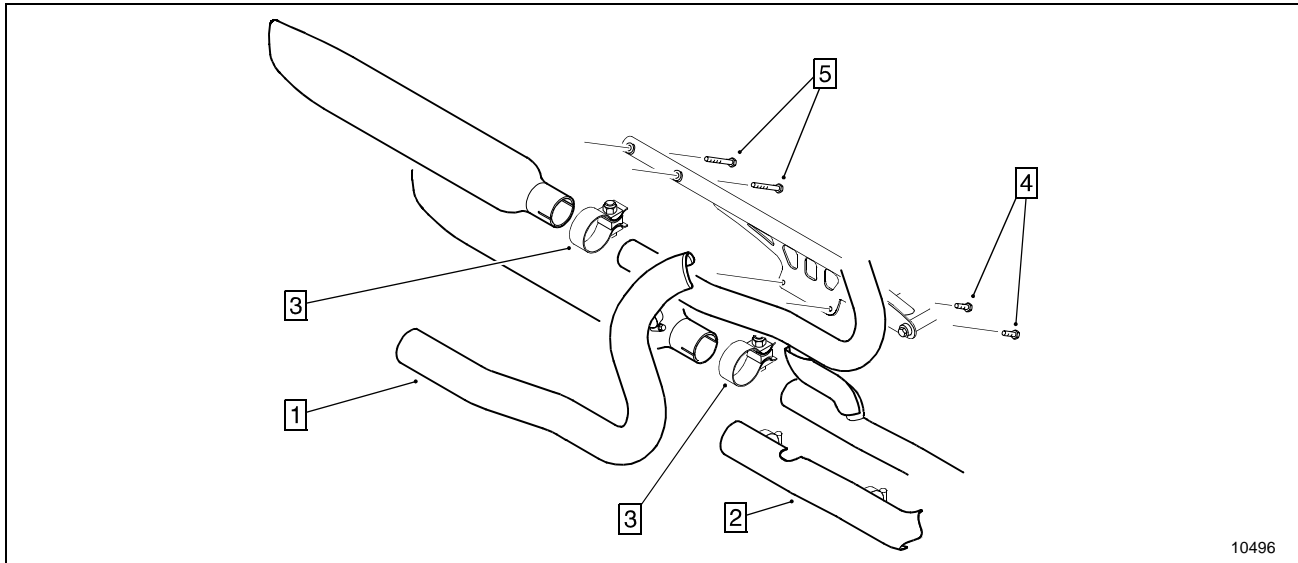

Figure 2

- 1. Rear Cylinder Heat Shield
- 2. Lower Front Cylinder Heat Shield
- 3. Muffler Clamp
- 4. Front Muffler Mounting Bolt (1")
- 5. Rear Muffler Mounting Bolt (2")

8. Thoroughly clean both slash-cut mufflers with window cleaner or chrome polish before starting the motorcycle.

**NOTICE**

Oil, grease, and fingerprints can permanently damage chrome plated finishes when heated to extreme temperatures.



**EXCELSIOR-HENDERSON MOTORCYCLE MANUFACTURING COMPANY**

805 HANLON DRIVE · BELLE PLAINE, MINNESOTA 56011 · TELE: 612.873.7000/FAX: 612.873.7030 · [www.excelsior-henderson.com](http://www.excelsior-henderson.com)

Excelsior-Henderson™, Super X™, Rider's Handbook™, and the X & Bar logo are registered trademarks of the Excelsior-Henderson Motorcycle Manufacturing Company. Loctite® is a registered trademark of the Loctite Corporation. Always ride safely, within the limits of the law, and your riding ability. Never ride under the influence of alcohol or drugs. Know your Excelsior-Henderson motorcycle and read your Rider's Handbook from cover to cover. We recommend you take a Motorcycle Safety Foundation Rider Education Course (for a course near you call 1.800.447.4700). We also recommend that you always wear a helmet, appropriate protective eyewear, and appropriate clothing, and that you insist your passenger does the same. However, we respect your right as an individual to make your own choice about the protective equipment you wear (within the limits of the law). Protect your privilege to ride by joining the American Motorcyclist Association.